

All dimensions shown are in millimetres

- Test pressure: **24 BAR**
- Max. working pressure: **16 BAR**
- Max working temperature: **120° C**
- Aluminium construction: **cast headers with 35mm dia tubes**
- Connections: **½ inch BSP bottom opposite end tappings**

Heat output determined in accordance with EN 442

Manufactured for Bisque by Fondital of Italy

Model	Output ΔT=30K Watts	Output ΔT=50K Watts	n	Water Content litres	Weight kg	Height ± 2mm	Length ± 2%	Tapping Centres ± 2mm	Fixing Centres ± 2mm
TEF-58-60	383	732	1.27	13.8	11	639	600	n/a	n/a
TEF-58-80	510	976	1.27	18.4	14	639	800	n/a	n/a
TEF-58-100	638	1220	1.27	23.0	18	639	1000	n/a	n/a
TEF-58-120	765	1464	1.27	27.6	22	639	1200	n/a	n/a

**Tools & Material Required**

- Suitable valves
- PTFE tape
- Silicone thread sealant
- Tape measure
- Allen key - 13mm & 12mm (when installing Bisque valves)
- Screwdriver
- Electric drill
- Masonry drill bit - 7mm diameter
- Spirit level
- Stepladder

Key	Component	Qty
A	Diverter	1
B	Plastic Spanner	1
C	End Cap - righthand thread	2
D	End Cap - lefthand thread	2
E	Air Vent	1
F	Blanking Plug	1
G	Cap	2
H	Wall Plug*	2
I	Collar	2
J	Screw - dia 6 x 65*	2
K	Bracket	2
L	Adjusting Screw	2
M	Clamp - lefthand	2
N	Clamp - righthand	2
O	Screw M5	2
P	Nut M5	2
Q	Bracket Cover	2

**Assembly Instructions**

**Sufficient PTFE tape must be applied to valve-tail threads prior to their installation.**  
 Silicone thread sealant should be applied to all threaded components manufactured with 'O-rings'.

*\*The screws & plugs supplied are for solid walls only. Please use appropriate fixings for the type of wall that the radiator is being installed onto.*

Using the handle of a screwdriver, push diverter (A) into flow side until resistance is felt (about 35mm).

Using plastic spanner (B) and ensuring o-rings are seated properly, screw end caps (C & D) to radiator. Please note that two of the caps have a lefthand thread so will need to be screwed in anti-clockwise.

Fit air vent (E), blanking cap (F) and cover caps (G).

Accurately mark out 2 bracket holes on wall to dimensions as shown on Technical Data Sheet.

Drill 8mm diameter holes in wall to a minimum depth of 65mm and insert wall plugs (H).

Ensuring collar (I) is around screw (J), fix brackets (K) to wall.

Loosely fit adjusting screw (L) into top of bracket (K).

Assemble lefthand (M) and righthand (N) clamps onto radiator using screw (O) and nut (P).

Fix radiator onto wall.  
*note: radiator **must** be secured to wall using top brackets*

Fit bracket cover (Q).

Plumb radiator to heating circuit with flow opposite air vent.

Air vent is recessed so flathead screwdriver must be used to vent radiator.

This radiator should be installed onto a central heating system that has been cleaned/flushed and contains water treatment and inhibitors in accordance with BS7593.

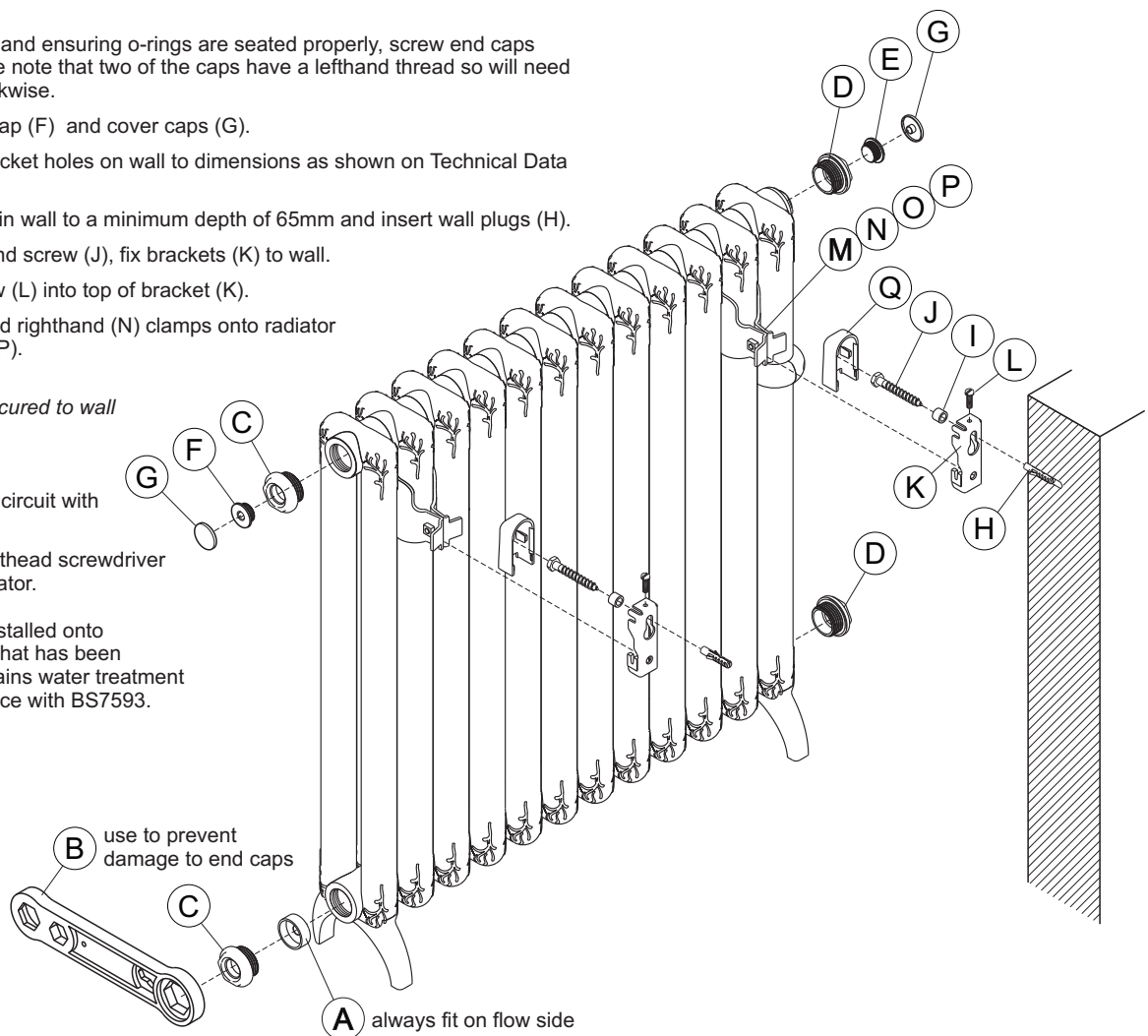

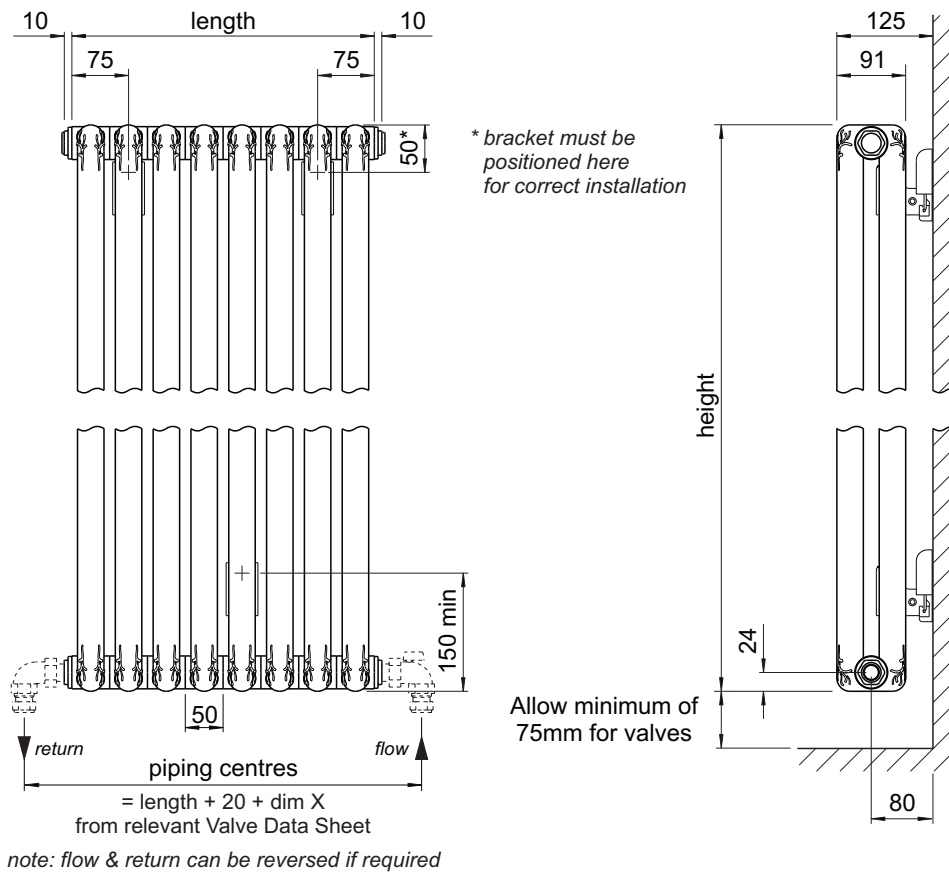

All dimensions shown are in millimetres

- Test pressure: **24 BAR**
- Max. working pressure: **16 BAR**
- Max working temperature: **120° C**
- Aluminium construction: **cast headers with 35mm dia tubes**
- Connections: **½ inch BSP bottom opposite end tappings**

Heat output determined in accordance with EN 442

Manufactured for Bisque by Fondital of Italy

Model	Output $\Delta T=30K$ Watts	Output $\Delta T=50K$ Watts	n	Water Content litres	Weight kg	Height $\pm 2mm$	Length $\pm 2\%$	Tapping Centres $\pm 2mm$	Fixing Centres $\pm 2mm$
TEW-75-30	239	460	1.28	7.1	6	749	300	n/a	n/a
TEW-75-40	319	614	1.28	9.4	8	749	400	n/a	n/a
TEW-75-50	399	767	1.28	11.8	10	749	500	n/a	n/a
TEW-75-60	478	920	1.28	14.2	12	749	600	n/a	n/a
TEW-148-30	459	887	1.29	14.2	10	1484	300	n/a	n/a
TEW-148-40	612	1182	1.29	18.9	13	1484	400	n/a	n/a
TEW-148-50	765	1478	1.29	23.6	16	1484	500	n/a	n/a
TEW-178-30	550	1068	1.30	17.1	12	1784	300	n/a	n/a
TEW-178-40	733	1424	1.30	22.8	16	1784	400	n/a	n/a
TEW-178-50	916	1780	1.30	28.5	20	1784	500	n/a	n/a
TEW-178-60	1100	2136	1.30	34.2	24	1784	600	n/a	n/a

### Tools & Material Required

Suitable valves  
 PTFE tape  
 Silicone thread sealant  
 Tape measure  
 Allen key - 13mm & 12mm (when installing Bisque valves)  
 Screwdriver  
 Electric drill  
 Masonry drill bit - 7mm diameter  
 Spirit level  
 Stepladder

Key	Component	Qty
A	Diverter	1
B	Plastic Spanner	1
C	End Cap - righthand thread	2
D	End Cap - lefthand thread	2
E	Air Vent	1
F	Blanking Plug	1
G	Cap	2
H	Wall Plug*	3
I	Collar	3
J	Screw - dia 6 x 65*	3
K	Bracket	3
L	Adjusting Screw	3
M	Clamp - lefthand	3
N	Clamp - righthand	3
O	Screw M5	3
P	Nut M5	3
Q	Bracket Cover	3

### Assembly Instructions

**Sufficient PTFE tape must be applied to valve-tail threads prior to their installation.**

Silicone thread sealant should be applied to all threaded components manufactured with 'O-rings'.

Using the handle of a screwdriver, push diverter (A) into flow side until resistance is felt (about 35mm).

Using plastic spanner (B) and ensuring o-rings are seated properly, screw end caps (C & D) to radiator. Please note that two of the caps have a lefthand thread so will need to be screwed in anti-clockwise.

Fit air vent (E), blanking cap (F) and cover caps (G).

Accurately mark out 3 bracket holes on wall to dimensions as shown on Technical Data Sheet.

Drill 8mm diameter holes in wall to a minimum depth of 65mm and insert wall plugs (H).

Ensuring collar (I) is around screw (J), fix brackets (K) to wall.

Loosely fit adjusting screw (L) into top of bracket (K).

Assemble lefthand (M) and righthand (N) clamps onto radiator using screw (O) and nut (P).

Hang radiator onto wall and level using adjusting screw (L).

Fit bracket cover (Q).

Plumb radiator to heating circuit with flow opposite air vent.

Air vent is recessed so flathead screwdriver must be used to vent radiator.

This radiator should be installed onto a central heating system that has been cleaned/flushed and contains water treatment and inhibitors in accordance with BS7593.

\*The screws & plugs supplied are for solid walls only. Please use appropriate fixings for the type of wall that the radiator is being installed onto.

