

All dimensions shown are in millimetres

Max working pressure: **5 BAR**
 Max working temperature: **120° C**
 All steel construction: **dia 31.8mm round tubes**
 Connections: **½ inch BSP tapings**

Heat output determined in accordance with EN 442

Model	Output $\Delta T=30K$ Watts	Output $\Delta T=50K$ Watts	n	Water Content litres	Weight kg	Height $\pm 2mm$	Length $\pm 2mm$	Tapping Centres $\pm 2mm$	Fixing Centres $\pm 5mm$
BALM	355	683	1.31	10	24	850	735	n/a	n/a

Tools & Material Required

Suitable valves
 PTFE tape
 Silicone thread sealant
 Allen key - 13mm & 12mm (when installing Bisque valves)
 Spanner - 13mm & 14mm
 Screwdriver - flathead
 Electric drill
 Masonry drill bit

Key	Component	Qty
A	Air Vent	1
B	Screw	12

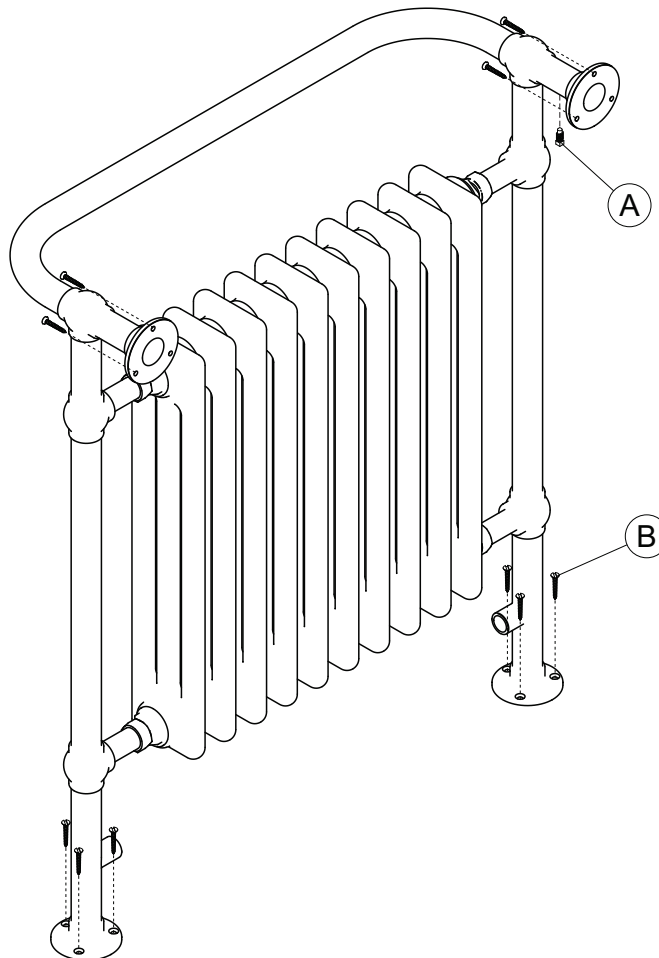
**Assembly Instructions**

Sufficient PTFE tape must be applied to valve-tail threads prior to their installation.
 Silicone thread sealant should be applied to all threaded components manufactured with 'O-rings'.

Fit valve tails, using correct size Allen key.

Fit air vent (A).

Accurately mark out bracket holes on floor & wall.

Drill twelve fixing holes. Screws (B) are supplied but ensure that appropriate fixings are used for the type of wall the radiator is being mounted on.

Screw radiator to floor & wall.

Plumb radiator to heating circuit. To enable more efficient bleeding of the radiator, it is recommended that the flow enters the radiator in the right-hand header.

This radiator should be installed onto a central heating system that has been cleaned/flushed and contains water treatment and inhibitors in accordance with BS7593.