

* This dim may be reduced by 5mm by turning the bracket upside down

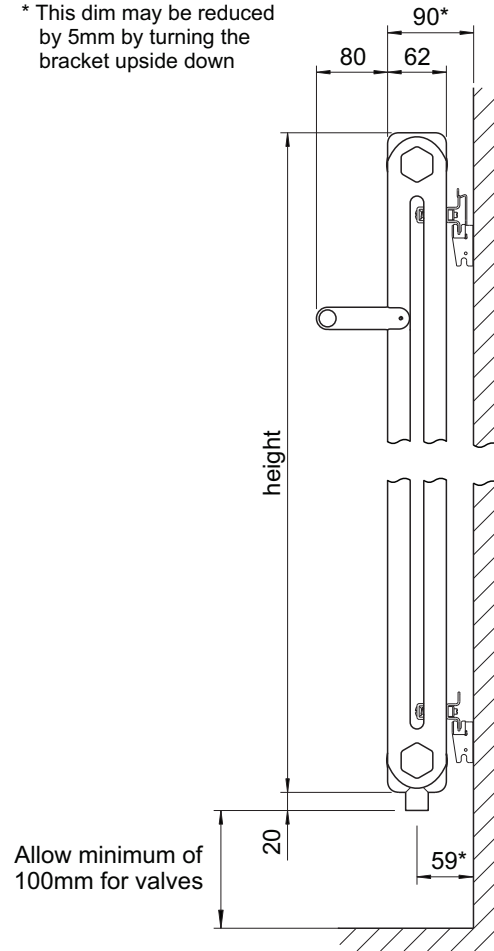

Test pressure: **15 BAR**
 Max. working pressure: **10 BAR**
 Max working temperature: **120° C**
 All steel construction: **25mm dia tubes**
 Connections: **½ inch BSP underside tapings**

All dimensions shown are in millimetres

Heat output determined in accordance with EN 442

Manufactured for Bisque by Zehnder of Germany

Model	Output $\Delta T=30K$ Watts	Output $\Delta T=50K$ Watts	n	Water Content litres	Weight kg	Height $\pm 2mm$	Length $\pm 1.5\%$	Tapping Centres $\pm 2mm$	Fixing Centres $\pm 2mm$
CT-75-37	232	440	1.25	5.6	9.3	742	394	326	184
CT-75-46	290	550	1.25	7.0	11.6	742	486	418	276
CT-75-55	349	660	1.25	8.4	13.9	742	578	510	368
CT-75-64	407	770	1.25	9.8	16.2	742	670	602	460
CT-120-37	350	662	1.25	8.8	14.4	1192	394	326	184
CT-120-46	437	827	1.25	11.0	18.0	1192	486	418	276
CT-150-28	324	624	1.28	7.8	13.8	1492	302	234	92
CT-150-37	433	832	1.28	10.4	18.4	1492	394	326	184
CT-150-46	541	1040	1.28	13.0	23.0	1492	486	418	276
CT-180-28	381	744	1.31	9.0	16.2	1792	302	234	92
CT-180-37	508	992	1.31	12.0	21.6	1792	394	326	184
CT-180-46	635	1240	1.31	15.0	27.0	1792	486	418	276
CT-180-55	762	1488	1.31	18.0	32.4	1792	578	510	368

Tools & Material Required

- Wall plugs - 10mm
- Screws - 7mm diameter x 60mm length
- Suitable valves
- PTFE tape
- Silicone thread sealant
- Tape measure
- Allen key - 13mm & 12mm (when installing Bisque valves)
- Spanner - 13mm & 14mm
- Socketdriver - 10mm long reach
- Electric drill
- Masonry drill bit - 10mm diameter
- Spirit level
- Stepladder

Key	Component	Qty
A	Air Vent - 1/2" (factory fitted)	1
B	Wall Plug*	4
C	Bracket	4
D	Screw - Hex Head, 7mm dia x 60mm*	4
E	Clamp Assembly	4
F	Security Clip	2
G	Towel Rail	1
H	End Cap - Towel Rail	2
I	Felt Strip	2
J	Bracket - Towel Rail	2
K	Grub Screw	6
L	Allen Key	1

* Wall Plugs & Screws not supplied

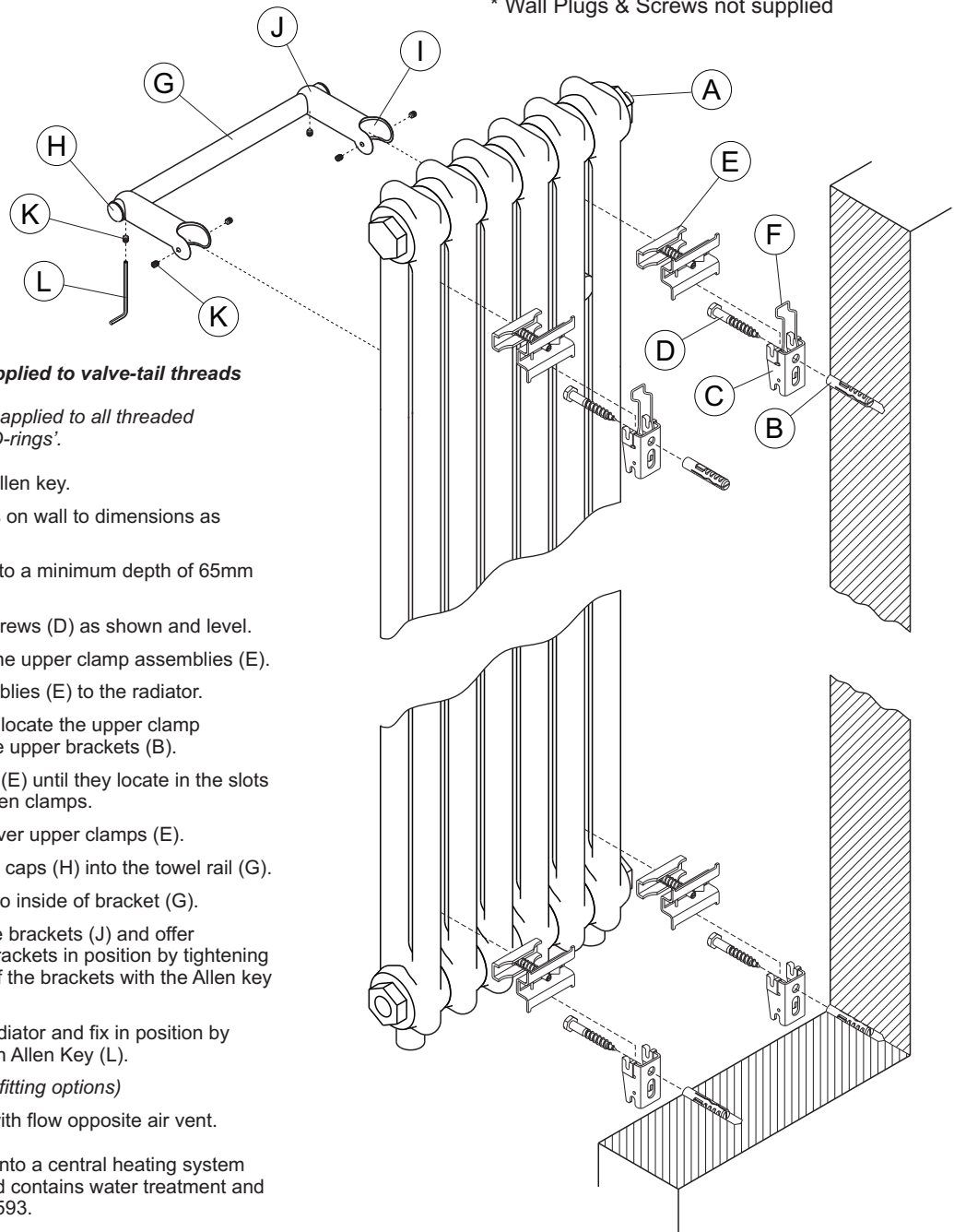

Assembly Instructions

Sufficient PTFE tape must be applied to valve-tail threads prior to their installation.
 Silicone thread sealant should be applied to all threaded components manufactured with 'O-rings'.

- Fit valve tails, using correct size Allen key.
- Accurately mark out bracket holes on wall to dimensions as shown on Technical Data Sheet.
- Drill 10mm diameter holes in wall to a minimum depth of 65mm and insert wall plugs (B).
- Attach brackets (C) to wall with screws (D) as shown and level.
- Tightly fix the radiator tubes into the upper clamp assemblies (E).
- Loosely fit the lower clamp assemblies (E) to the radiator.
- Lift the radiator on to the wall and locate the upper clamp assemblies (E) into the slots in the upper brackets (B).
- Slide the lower clamp assemblies (E) until they locate in the slots in the lower brackets (B) and tighten clamps.
- Fix security clip (F) into position over upper clamps (E).
- If not already fitted, screw the end caps (H) into the towel rail (G).
- Fit the self-adhesive felt strips (I) to inside of bracket (G).
- Slide the towel rail (G) through the brackets (J) and offer assembly up to radiator. Fix the brackets in position by tightening the grub screws (K) in the sides of the brackets with the Allen key (L) supplied.
- Centre the towel rail (G) on the radiator and fix in position by tightening the grub screws (K) with Allen Key (L).
- (See separate sheet for towel rail fitting options)*
- Plumb radiator to heating circuit with flow opposite air vent.

This radiator should be installed onto a central heating system that has been cleaned/flushed and contains water treatment and inhibitors in accordance with BS7593.